

Industrial pH Sensor

MS pH 02 (Origin USA)



FEATURE

- Four Ceramic Junction → Fast Response due to increased porosity, Increased Sensor Life
- Filled with Gel → Helps to maintain zero potential for longer time
- Industrial Grade Rugged Construction
- Easy Installation

DESCRIPTION

MicroSet make pH Sensor model MS pH 02 is designed for various Industrial Applications. Four ceramic junction reference aids in the sensor's resistance to harsh environments and helps prolong sensor life. The robust sensor design makes the MS pH 02 reliable in a wide range of aqueous solutions found in pipelines, open tanks or ponds.

TECHNICAL SPECIFICATION

Range	: 0 to 14 pH
Body	: Derlin
Type	: Combination
Sensor Output	: mV (± 59.4 mV/pH change at 25°C)
Pressure	: 6 Bar
Temperature	: 0 ~ 100°C
Temperature Compensation	: Pt 100 (Optional)
Junction	: Four Ceramic
Process Connection	: $\frac{3}{4}$ " BSP Male on Front End and Rear End
Mounting	: Pipeline (Inline) or Immersion (Tank) or Flow Through Chamber
Cable	: Standard Integral Cable 5 Meter with BNC (Optional Leads) Cable Length: 10, 15, 20, 25 Meters Also Available (Optional At Extra Cost) Please specify Cable Length required while ordering Note: Integral Cable Cannot Be Extended from 5 Mtrs. to 10 Mtrs. or so.

APPLICATION

Water Treatment Plant (WTP)

Effluent Treatment Plant (ETP)

RO Water Plant

Hydroponics

Textile Industry

Beverages / Food Industry

Wastewater Treatment Plant (WWTP)

Sewage Treatment Plant (STP)

Power Plant

Chemical Industry

Paper & Pulp

Pharma Industry

DIMENSION

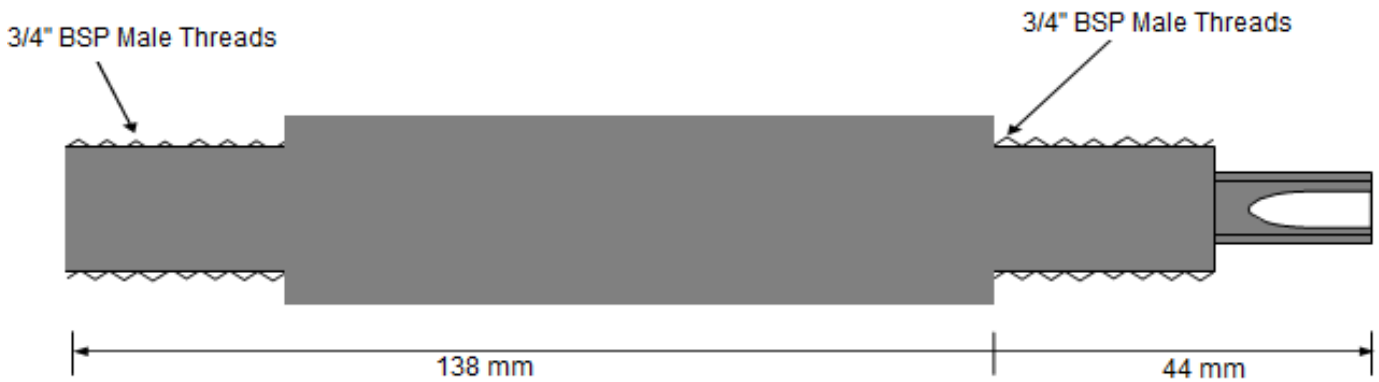

INSTALLATION

1. PIPELINE (IN-LINE) INSTALLATION

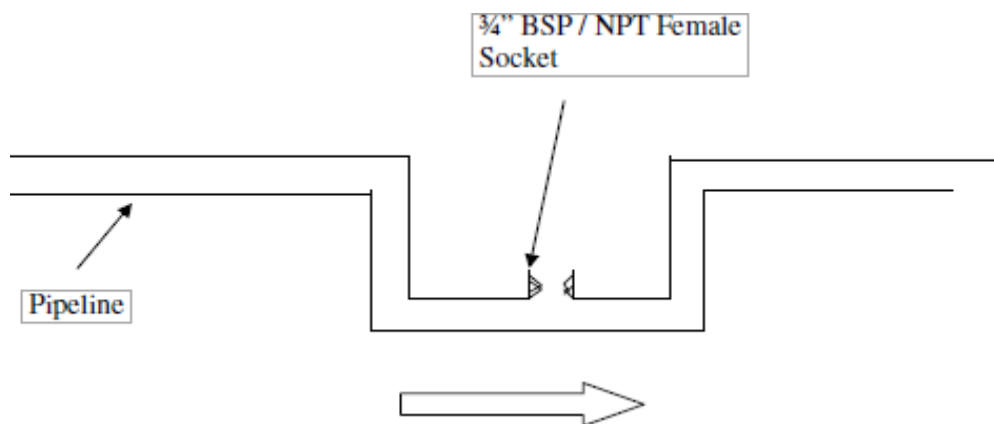

2. IMMERSION (TANK) INSTALLATION

A. GA Diagram for Guide Pipe / Dip Pipe for Tank:

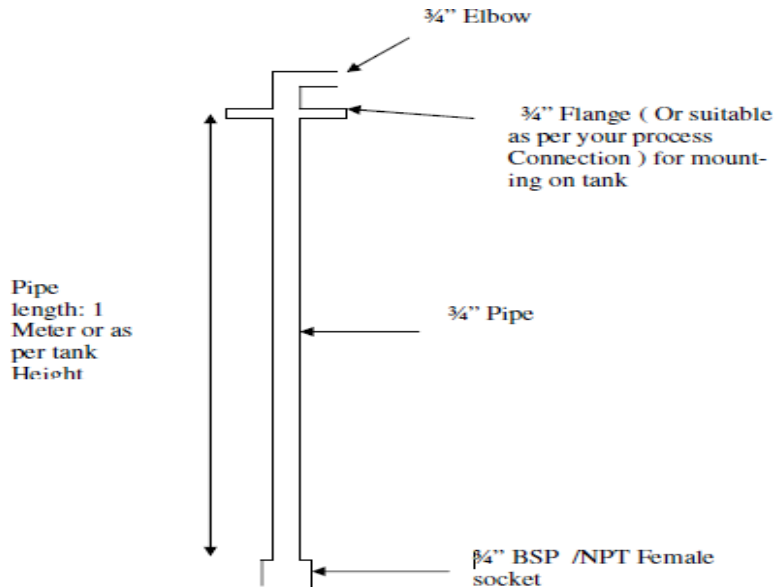

MOC of Pipe / Socket / Flange : SS304 / SS 316 / PP / PVC as per Application
 Note: Fabricate the dip pipe in a way that pH sensor should always dip in solution

B. GA Diagram for pH Sensor Installation in Tank

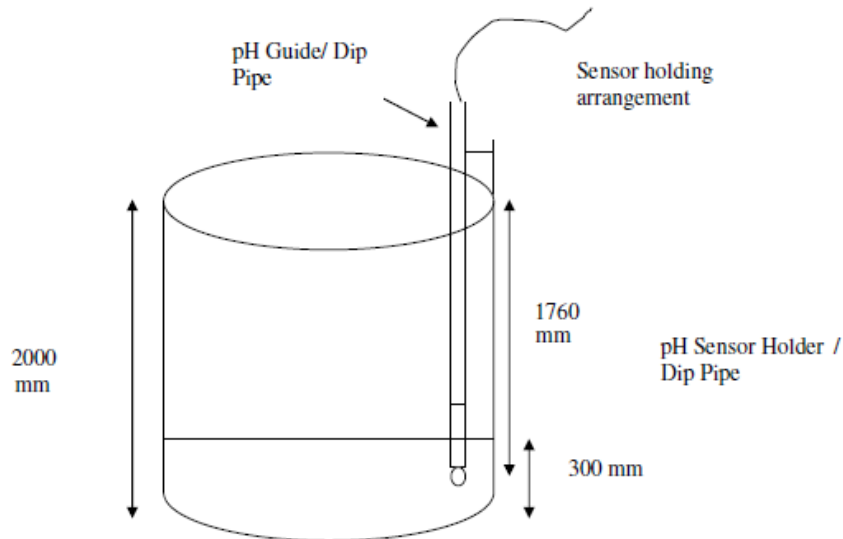

Example:

- Tank Height : 2000 mm
- Minimum Water Level : 300 mm
- pH Sensor with Dip Pipe Length: 1760 mm (from top). Sensor should be installed in a way that the sensor should not dry at any cost.

Note : Due to continuous improvement in product, specifications & looks may vary